



Also Available in
Sweat Connection

Belimo ZoneTight™ Zone Valves Technical Documentation

Table of Contents

Overview	3
QCV Nomenclature	5
PIQCV Nomenclature	7
Set-Up	9
Accessories	10
Flow Pattern	11
Piping	12
Field-Set Adjustment	14
Installation	15
Wiring	16
Flow Verification	18
Troubleshooting	21
Valve Specification and Dimensions	22
Actuator Specification	25
Flow Curves	26
Terms and Conditions	28

Designed for maximum efficiency in tight spaces, Belimo's ZoneTight valve offering sets new design and performance standards for both pressure dependent and pressure independent zoning applications.

ZoneTight Zone Valve (QCV)

The ultra-compact QCV leads the way in Belimo's new generation of room and zone solutions. Equipped with a space-saving 2-way or 3-way ball valve and an electronic rotary actuator, the QCV has an installation height of just 4.33 inches (110 mm), available NPT or Sweat, and offers a number of benefits over conventional pressure dependent control valves, including:

- Belimo ball valve design with zero leakage eliminates energy loss.
- Self-cleaning ball valve technology provides superior clog resistance.
- Low power consumption up to 95% less than conventional zone valves.
- Field adjustable Cv value to meet your design requirements.

ZoneTight Pressure Independent Zone Valve (PIQCV)

The PIQCV offers all the advantages of a Pressure Independent Characterized Control Valve (PICCV) but in an ultra compact configuration. The PIQCV combines a differential pressure regulator with a 2-way control valve to supply a specific flow for each degree of ball opening regardless of system pressure fluctuations. The valve performs the function of a balancing valve and control valve in one unit.

- Smallest pressure independent characterized ball valve in the market.
- Actuator runs at 0.3 W saving energy and transformer power.
- Flow is adjustable at the actuator and always perfectly balanced.
- Permits PIV installation in tight spaces.

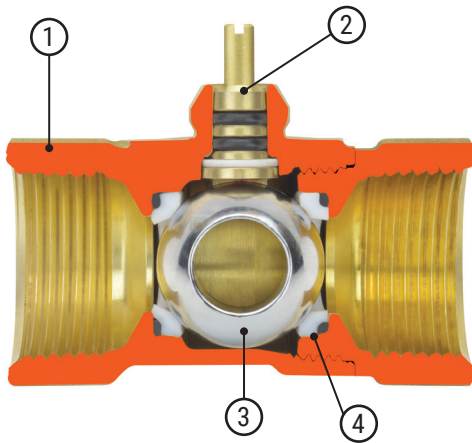
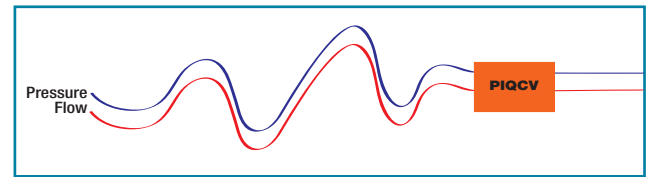

ZoneTight Zone Valve

Valve body	Control valve (QCV)
① Body NPT or Sweat	② Stem
	③ Ball with profile
	④ Seat

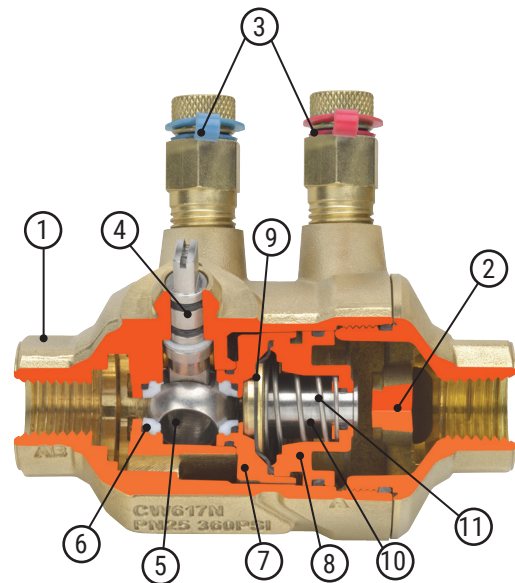

ZoneTight Pressure Independent Zone Valve

Valve body	Control valve (PIQCV)	Regulator
① Body	④ Stem	⑦ Regulator Cap
② End Cap	⑤ Ball with profile	⑧ Regulator Body
③ PT Ports	⑥ Seat	⑨ Diaphragm
		⑩ Regulator Shaft
		⑪ Regulator Spring

Tech.Doc - 11/24 - Subject to change. © Belimo Aircontrols (USA), Inc.

ZoneTight Features

Compact Design

When faced with limited available mounting space, the Belimo ZoneTight valve's super-compact design helps maximize workable space and complements OEM valve compartment optimization.

Ball Valve Technology

Unlike short stroke globe valves with plug and seat design, the self-cleaning ball helps minimize energy losses caused by clogging (0% A to AB leakage) and eliminates seat leakage. The intuitive configuration also allows for bi-directional flow (QCV) unlike traditional paddle style zone valves. In addition, equal percentage flow characteristic provides superior part load coil performance.



Actuator with Patented Brushless DC Motor

The brushless DC motor's power consumption when running is a mere 0.3W, 0.15W when holding, saving energy and transformer power. In addition to significantly reducing energy costs, this helps eliminate failures due to stalled motors and prolongs actuator life. It also allows for more units to be powered by a single transformer.

Snap Fit

The QCV and PIQCV easily connects to the actuator allowing operators and technicians to install valves quickly, easily, and without the use of tools. This helps simplify commissioning and reduces labor costs.



Field Adjustable Max Cv/Flow

QCVs and PIQCVs can be quickly and easily field adjusted to ensure that necessary design requirements are met and reduces inventory.



Stem Extension for Insulation

Unlike conventional zone valve actuators, which are normally covered by pipe insulation, the stem extension on QCVs and PIQCVs allows for easy actuator removal without damaging the surrounding insulation, helping simplify operation and maintenance activities.

ZoneTight Zone Valve (QCV) Nomenclature

Z2	050	Q	S	-J	+CQB	24	-SR	-L	
Valve Type Z2 = 2-way Z3 = 3-way ZoneTight Chrome Plated Brass Ball and Brass Stem	Valve Size 050 = 1/2" 075 = 3/4" 100 = 1"	Quick Connect	Connection Type Blank = NPT S = Sweat	Cv 2-way F = 1.4 J = 5.9 K = 9.8 3-way* E = 1 H = 2.7 J = 4.6	Actuator Type Non Fail-Safe CQB CQX Electronic Fail-Safe CQKB CQKX	Power Supply 24 = AC/DC 24 V UP = AC 100...240 V	Control -3 = On/Off, Floating Point -SR = Modulating Input = 2...10 V	Direction of Rotation -L = Open (2 V) -R = Close (2 V) -LL = Normally Open, Fail Open -RR = Normally Close, Fail Close -LR = Normally Open, Fail Close -RL = Normally Close, Fail Open	-S = Built-in Aux. Switch

"X" models are customizable.
Refer to page 6 for factory set clip position options.

*On/off only.

Ordering Example

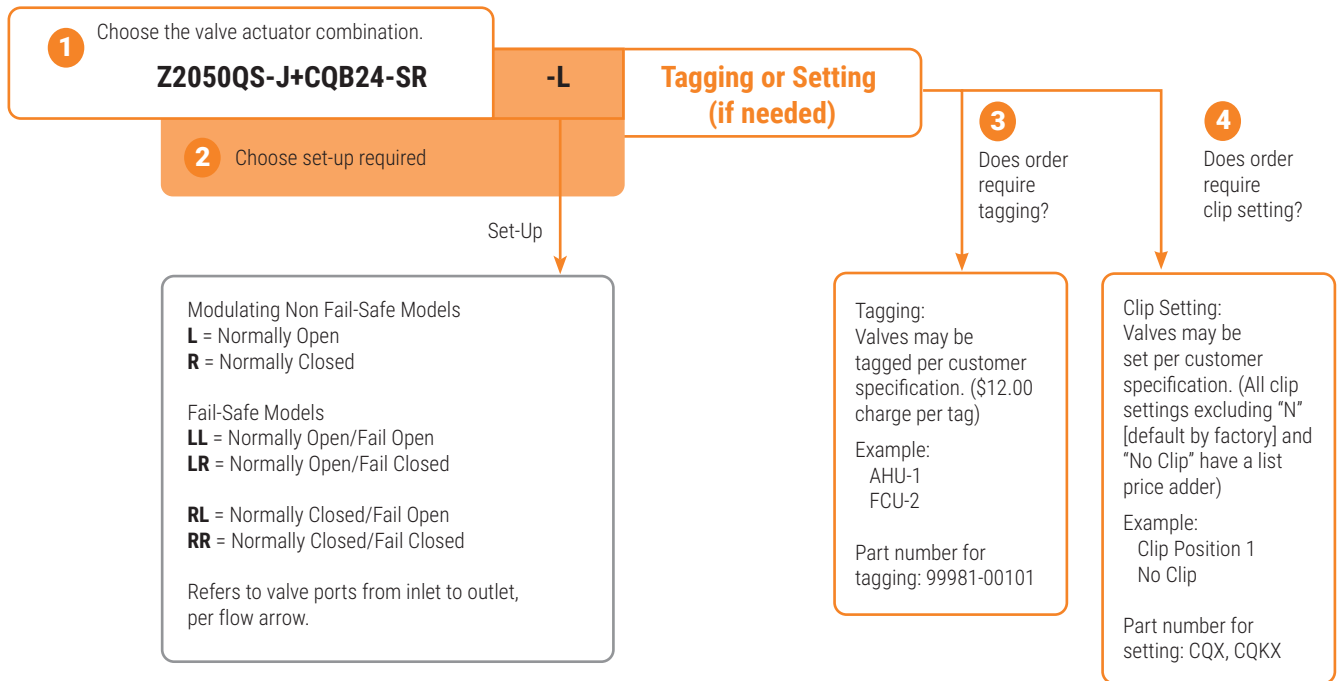

Modulating Non Fail-Safe Models
L = Normally Open
R = Normally Closed

Fail-Safe Models
LL = Normally Open/Fail Open
LR = Normally Open/Fail Closed

RL = Normally Closed/Fail Open
RR = Normally Closed/Fail Closed

Refers to valve ports from inlet to outlet, per flow arrow.

Tagging:
 Valves may be tagged per customer specification. (\$12.00 charge per tag)

Example:
 AHU-1
 FCU-2

Part number for tagging: 99981-00101

Clip Setting:
 Valves may be set per customer specification. (All clip settings excluding "N" [default by factory] and "No Clip" have a list price adder)

Example:
 Clip Position 1
 No Clip

Part number for setting: CQX, CQKX

Belimo ZoneTight Zone Valves

QCV Product Range



	Valve Nominal Size			Type		Suitable Actuators	
	C _v	Inches	DN [mm]	2-way	3-way	Non Fail-Safe	Fail-Safe
NPT	1.4*	½	15	Z2050Q-F		CQ Series	CQK Series
	5.9*	½	15	Z2050Q-J			
	9.8*	¾	20	Z2075Q-K			
	8.2*	1	25	Z2100Q-K			
	1	½	15		Z3050Q-E		
	2.7	½	15		Z3050Q-H		
	4.6	¾	20		Z3075Q-J		
	4.4	1	25		Z3100Q-J		
Sweat	1.4*	½	15	Z2050QS-F		CQ Series	CQK Series
	5.9*	½	15	Z2050QS-J			
	9.8*	¾	20	Z2075QS-K			
	8.2*	1	25	Z2100QS-K			
	1	½	15		Z3050QS-E		
	2.7	½	15		Z3050QS-H		
	4.6	¾	20		Z3075QS-J		
	4.4	1	25		Z3100QS-J		

*Maximum flow. Max value can be field adjusted, see actuator instructions.
Order "X" model Actuators for Factory Clip Setting, see Instruction Manual for details.

	Clip Position for Flow Adjustment										No Clip
	1	2	3-	3	4	4+	5	5+	6	N	No end stop
Z2050Q(S)-F (½")	0.1	N/A	0.2	N/A	N/A	0.4	N/A	0.6	0.8	1.2	1.4
Z2050Q(S)-J (½")	0.5	0.7	N/A	1.2	1.7	N/A	2.4	N/A	3.4	4.8	5.9
Z2075Q(S)-K (¾")	0.5	1.0	N/A	1.5	2.3	N/A	3.3	N/A	4.6	6.6	9.8
Z2100Q(S)-K (1")	0.5	0.9	N/A	1.5	2.2	N/A	3.1	N/A	4.3	6	8.2

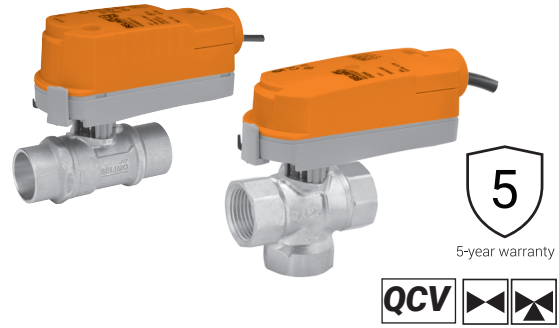

Mode of Operation

The ZoneTight Zone Valve (QCV) is operated by a rotary actuator. The actuators are controlled by a standard voltage for on/off control, a modulating signal, or floating point control system which moves the ball of the valve to the position dictated by the control system.

Product Features

The equal percentage characteristic of the flow is ensured by the design of the ball. This characteristic provides linear heating or cooling output from the coil improving energy efficiency and comfort.

Actuator Specifications

Control type	-3 on/off, floating point -SR modulating, 2...10 V Blank on/off
Manual override	use actuator to turn valve stem
Electrical connection	3 ft. [1 m] cable with ½" conduit fitting screw terminals
Power consumption	CQ.. 0.3 W running, 0.2 W holding CQK.. 2.5 W running, 0.5 W holding CQ..UP 1.0 W running, 0.7 W holding CQK..UP 3.0 W running, 0.5 W holding
Power supply	AC/DC 24 V (AC 100...240 V, UP)
Transformer sizing	CQ.. 0.6 VA CQK.. 5 VA CQ..UP 2 VA CQK..UP 7 VA

Valve Specifications

Fluid	chilled or hot water, 60% glycol
Flow characteristic	equal percentage (2-way) linear (3-way)
Controllable flow range	75° (2-way), 90° (3-way)
Sizes	½", ¾", 1"
End fitting	NPT female sweat
Materials	Body forged brass Ball chrome plated brass Stem brass Seats Teflon® PTFE O-rings EPDM (lubricated)
Fluid temp. range	36...212°F [2...100°C]**
Fluid temp. limit	250°F [120°C]**
Maximum allowable operating temperature	212°F [100°C]**
Body pressure rating	360 psi
Close-off pressure	75 psid (2-way), 40 psid (3-way)
Maximum differential pressure (ΔP)	40 psid
Leakage	0%

Teflon® is a registered trademark of DuPont™

**If temperature exceeds 212°F [100°C] operating range due to a boiler control failure the valve will safely contain the hot water but manufacturer's product warranty becomes invalid.

ZoneTight Pressure Independent Zone Valve (PIQCV) Nomenclature

Z2	050	Q	P	T	-B	+CQB	24	-SR	-R	
Valve Type Z2 = 2-way ZoneTight Chrome Plated Brass Ball and Brass Stem	Valve Size 050 = 1/2" 075 = 3/4"	Quick Connect	Pressure Independent	T = PT Port	Flow Rate B = 0.9 GPM D = 2.0 GPM F = 4.3 GPM G = 9.0 GPM	Actuator Type Non Fail-Safe CQB CQX Fail-Safe CQKB CQKX	Power Supply 24 = AC/DC 24 V UP = AC 110...240 V	Control -3 = Floating Point -SR = Modulating	Direction of Rotation -L = Open (2 V) -R = Close (2 V) -LL = Normally Open, Fail Open -RR = Normally Close, Fail Close -LR = Normally Open, Fail Close -RL = Normally Close, Fail Open	-S = Built-in Aux. Switch

"X" models are customizable.
Refer to page 8 for factory
set clip position options.

Ordering Example

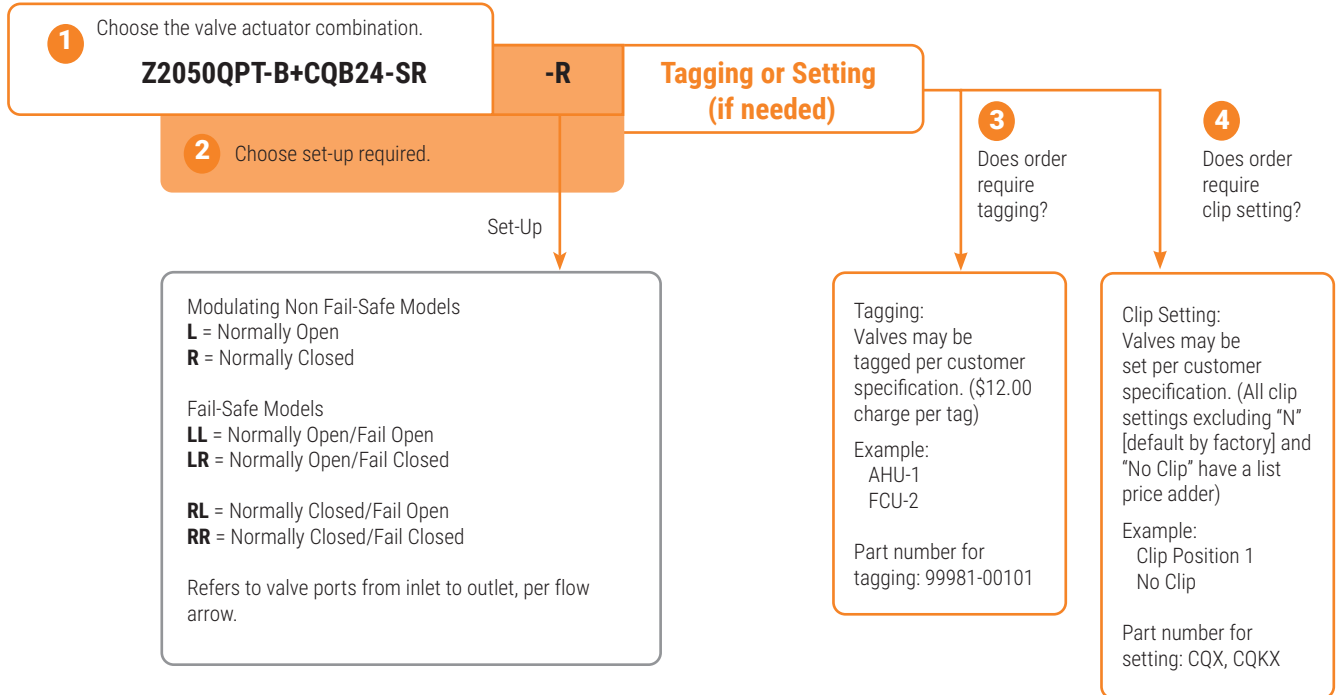

Tech.Doc - 11/24 - Subject to change. © Belimo Aircontrols (USA), Inc.

Belimo ZoneTight Zone Valves

PIQCV Product Range



GPM	Valve Nominal Size		Type	Suitable Actuators	
	Inches	DN [mm]		Non Fail-Safe	Fail-Safe
0.9*	½	15	Z2050QPT-B	CQ Series	CQK Series
2.0*	½	15	Z2050QPT-D		
4.3*	½	15	Z2050QPT-F		
9.0*	¾	20	Z2075QPT-G		

*Maximum flow value can be field adjusted, see actuator instructions.
Order "X" model actuators for Factory Clip Setting, see instruction manual for details.

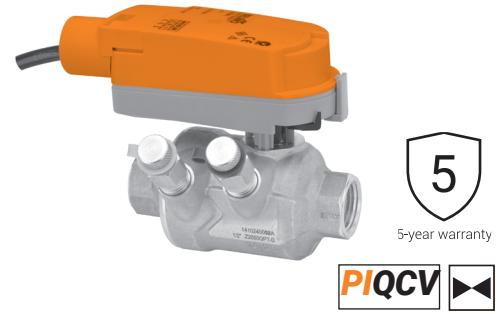

Mode of Operation

The ZoneTight Pressure Independent Zone Valve (PIQCV) is a two-way valve which combines the functionality of a control valve and a pressure regulating valve, creating one precise product which is unaffected by pressure variations in a system.

Product Features

Provides constant flow regardless of pressure variations in the system. Simplified valve sizing and selection, no Cv calculations required.

Actuator Specifications

Control type	-3 on/off, floating point -SR modulating, 0.5...10 V*, 2...10 V Blank on/off
Manual override	use actuator to turn valve stem
Electrical connection	3 ft. [1 m] cable with ½" conduit fitting screw terminals
Power consumption	CQ.. 0.3 W running, 0.2 W holding CQK.. 2.5 W running, 0.5 W holding CQ..UP 1 W running, 0.7 W holding CQK..UP 3.0 W running, 0.5 W holding
Power supply	AC/DC 24 V (AC 110...240 V, UP)
Transformer sizing	CQ.. 0.6 VA CQK.. 5 VA CQ..UP 2 VA CQK..UP 7 VA

Valve Specifications

Fluid	chilled or hot water, up to 60% glycol
Flow characteristic	equal percentage
Controllable flow range	75°
Sizes	½", ¾"
End fitting	NPT female
Materials	Body forged brass Ball stainless steel Stem stainless steel Seats Teflon® PTFE O-rings EPDM Spring stainless steel
Fluid temp. range	36...212°F [2...100°C]**
Fluid temp. limit	250°F [120°C]**
Maximum allowable operating temperature	212°F [100°C]**
PT ports	2
Body pressure rating	360 psi
Close-off pressure	200 psid
Differential pressure (ΔP) range	5...50 psid
Leakage	0%
Flow control tolerance	±5%

*Specify upon ordering.

**If temperature exceeds 212°F [100°C] operating range due to a boiler control failure the valve will safely contain the hot water but manufacturer's product warranty becomes invalid.

	Clip Position for Flow Adjustment (GPM)							
	1	2	3	4	5	6	N	No Clip
Z2050QPT-B (½")	N/A	N/A	N/A	N/A	0.4	N/A	0.8	0.9
Z2050QPT-D (½")	0.2	0.3	0.4	0.6	0.9	1.3	1.8	2.0
Z2050QPT-F (½")	N/A	0.6	0.8	1.3	1.9	2.8	3.6	4.3
Z2075QPT-G (¾")	N/A	1.8	2.7	3.7	4.9	6.3	7.7	9.0
Actuator Runtime	30 s	37 s	43 s	49 s	55 s	62 s	68 s	75 s

For additional intermediate settings see technical documentation or the ZoneTight flow capacity setting tool on www.belimo.us.





SET-UP - Specify Upon Ordering

2-WAY AND 3-WAY VALVES

NON FAIL-SAFE Stays in Last Position	CQB(X)UP-3	<p>On/Off: Power to brown wire (pin 2) will drive valve CW (closed). Power to brown wire (pin 3) and white wire (pin 3) will drive valve CCW (open).</p> <p>Floating: Power to brown wire (pin 2) will drive valve CW (closed). Power to white wire (pin 3) will drive valve CCW (open).</p>	
	CQB(X)24-3	<p>On/Off: Power to red wire (pin 2) will drive valve CW (closed). Power to red wire (pin 2) and white wire (pin 3) will drive valve CCW (open).</p> <p>Floating: Power to red wire (pin 2) will drive valve CW (closed). Power to white wire (pin 3) will drive valve CCW (open).</p>	
	CQB(X)24-SR	CQB24-SR-R: Normally closed, valve will open as voltage increases.	CQB24-SR-L: Normally open, valve will close as voltage increases.

ELECTRONIC FAIL-SAFE	CQKB(X)24 CQKB(X)24-S CQKB(X)UP	CQKB24-LL, CQKB24-S-LL, CQKBUP-LL: Normally open CCW, valve will drive closed when energized. Fail-Safe Action: Actuator will fail open CCW upon power loss.	CQKB24-RR, CQKB24-S-RR, CQKBUP-RR: Normally closed CW, valve will drive open when energized. Fail-Safe Action: Actuator will fail closed CW upon power loss.
	CQKB(X)24-SR	CQKB24-SR-RL: Normally closed CW, valve will open as voltage increases. Fail-Safe Action: Will fail open upon power loss.	CQKB24-SR-RR: Normally closed CW, valve will open as voltage increases. Fail-Safe Action: Will fail closed upon power loss.
		CQKB24-SR-LL: Normally open CCW, valve will close as voltage increases. Fail-Safe Action: Will fail open upon power loss.	CQKB24-SR-LR: Normally open CCW, valve will close as voltage increases. Fail-Safe Action: Will fail closed upon power loss.

*PIQCV are 2-way only.

ZONETIGHT VALVE ACCESSORIES		VALVE TYPE		
		Valves	Z2 (2-WAY)	Z3 (3-WAY)
	ZCQB-FL Flow setter	PIQCV	•	
		QCV	•	
	ZCQ-E QCV or PIQCV valve stem extension. Designed for chilled water service up to 104°F [40°C] media temperature	PIQCV	•	
		QCV	•	•
FLOW ORIFICE				
	FO15010 ½" Flow orifice for 1.0 GPM	PIQCV	•	
		QCV	•	
	FO15025 ½" Flow orifice for 2.5 GPM	PIQCV	•	
		QCV	•	
	FO15055 ½" Flow orifice for 5.5 GPM	PIQCV	•	
		QCV	•	
	FO20100 ¾" Flow orifice for 10.0 GPM	QCV	•	
	ARCHITECTURAL COVER			
	ZCQB-W Housing cover for CQ actuators (white)	PIQCV	•	
		QCV	•	•

QCV Flow Pattern

QCV 2-way valves can be piped with flow entering and exiting either port.

For on/off control of coil flow the QCV 3-way valve is piped with supply entering the bottom part.

For a QCV 3-way switching application, pipe hot and cold supply water to either side ports and the appropriate seasonal supply water will exit the bottom port for regulation by another 2-way valve; typically installed in the return pipe.

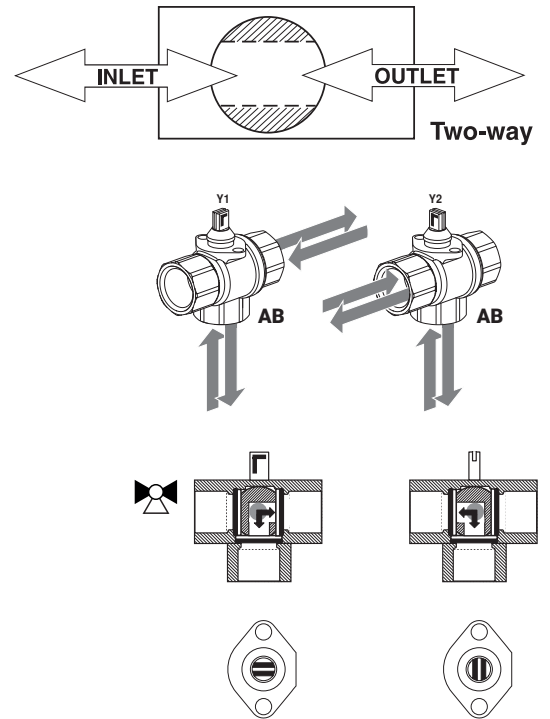

PIQCV Flow Pattern

The PIQCV consists of a differential pressure regulator and a control valve. The control valve is throttled to match the flow command of the control signal. The differential pressure regulator holds the pressure drop across the ball of the valve. As system pressure changes, the differential pressure regulator moves in response to keep the flow stable. Pressure (P1) at the inlet PIQCV is high and pressure (P3) at the outlet is low. The differential pressure between (P1) and (P3) must be between 5-50 to achieve pressure independent flow. When differential pressure increases the regulator opening is decreased. When differential pressure decreases the regulator opening is increased. This allows for the constant pressure differential across the ball of the valve.

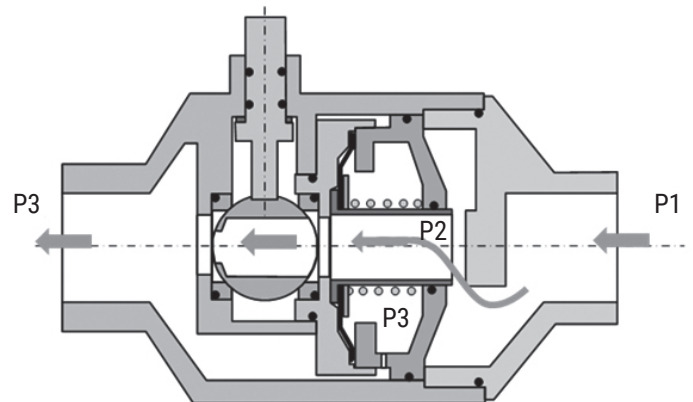

QCV Typical Piping

2-way Valve Piping Diagram

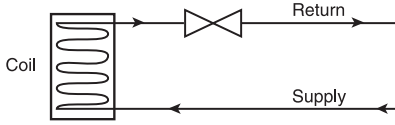

3-way Switching Valve Piping Diagram

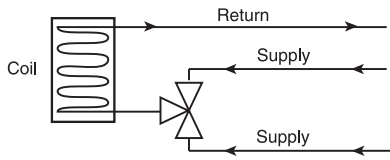

3-way Diverting Valve Piping Diagram

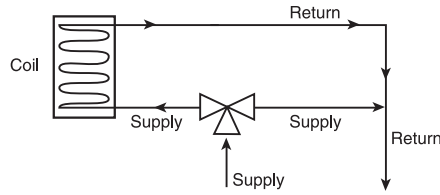

PIQCV Typical Piping

PIQCVs are recommended to be installed on the return side of the coil. This diagram represents a typical application. Consult engineering specification and drawings for project details. PT ports are recommended if not supplied on either side of the valve and the supply side of the heat transfer device to allow for pressure/flow measurement/calculation.

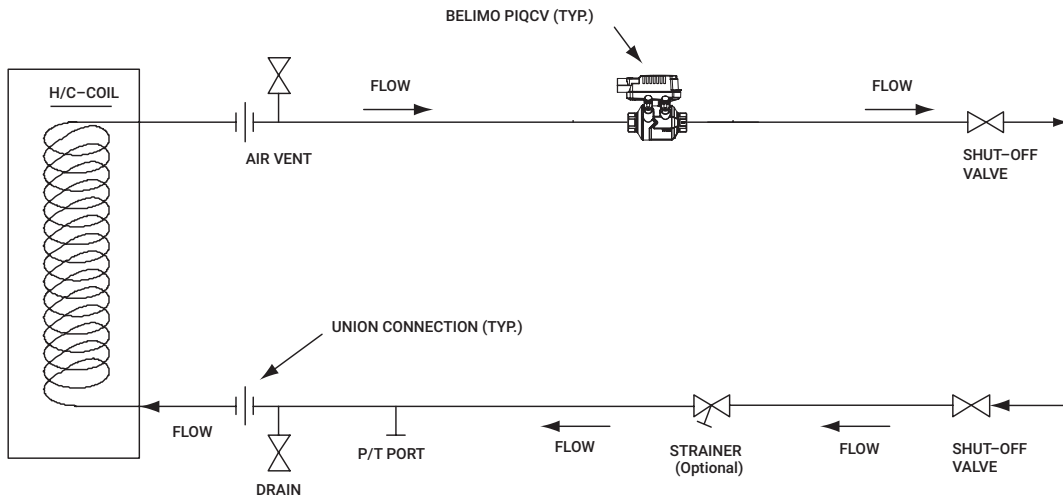

QCV/PIQCV Insulation & Orientation

Insulation should wrap the pipe and valve body but not the actuator. For chilled water applications use the stem extension kit accessory to raise the actuator above the valve body to provide space for insulation.

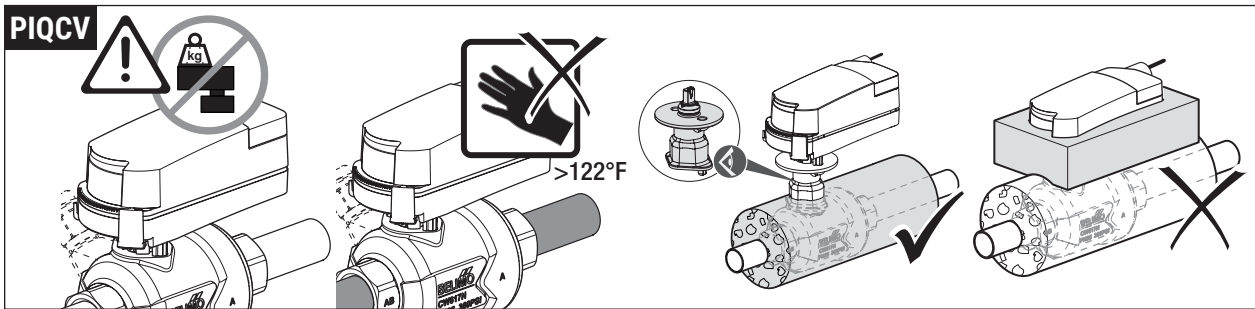
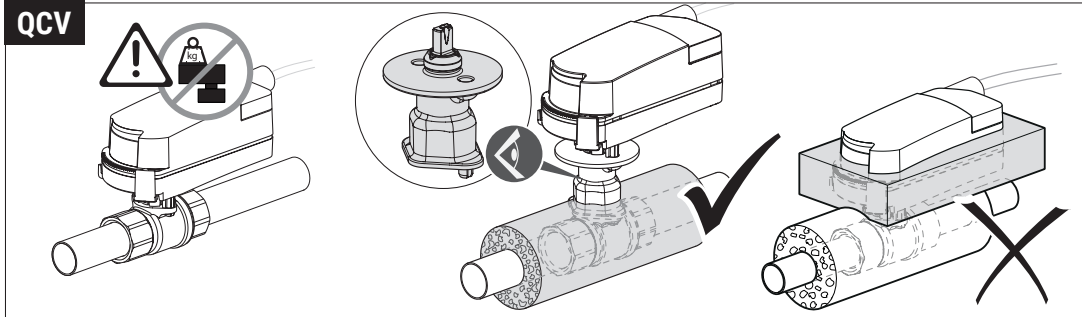

PIQCV's should be installed with flow in the direction of the arrow on the valve body. If installed backwards, there could be damage to either the diaphragm or the regulator. The valve assembly can be installed in a vertical or horizontal arrangement as long as the actuator is positioned to avoid water from dripping on the actuator.

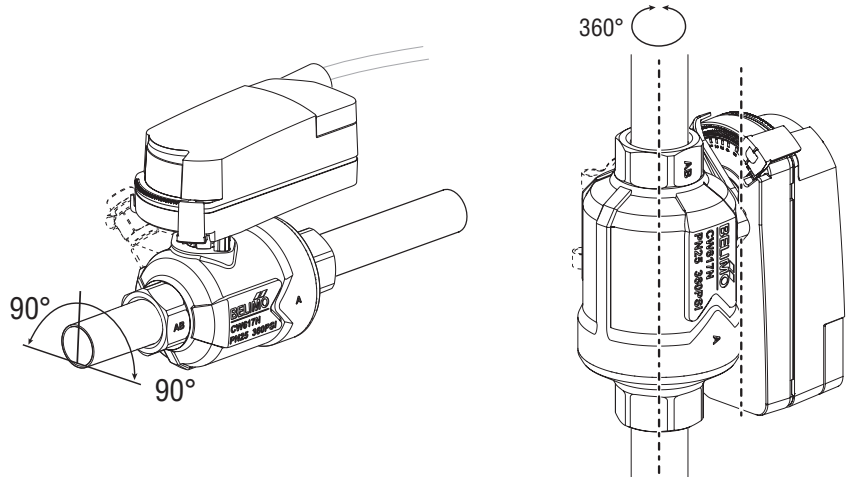
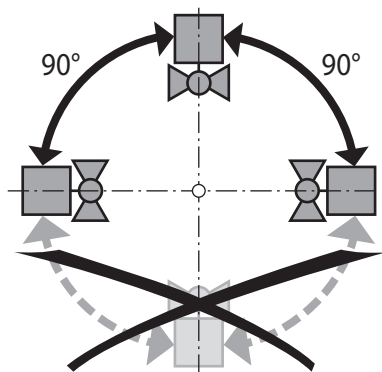

QCV/PIQCV Field-Set Flow Capacity Adjustment

Align the clip to the notch scale found on the underside of the actuator to the corresponding flow in the table below. For 3-point floating control signals adjust the controller runtime parameter to match the runtime of the of the final clip position. For analog 2-10 VDC control signals see adaption instructions.

For incremental notch settings refer to the flow graphs on page 25 or visit www.zonetight.com and put in your flow requirements to determine your notch position.

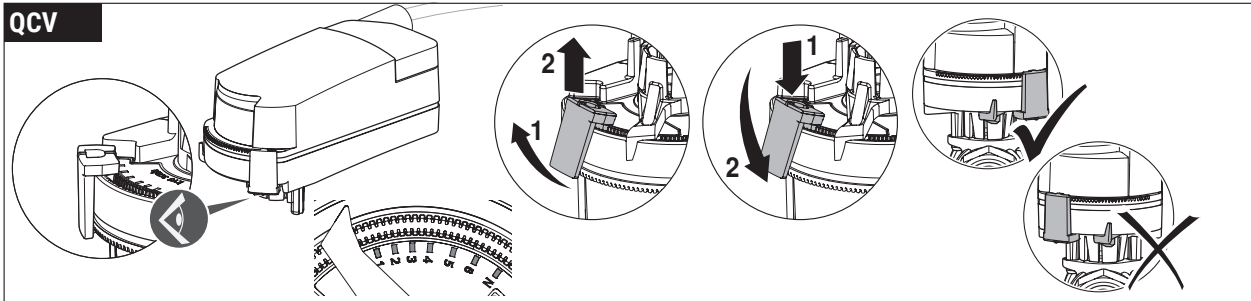

Size	Valve Model	V'max End Stop Positions										V'nom
		1	2	3-	3	4	4+	5	5+	6	N	No end stop
1/2"	Z2050Q(S)-F	0.1		0.2			0.4		0.6	0.8	1.2	1.4
1/2"	Z2050Q(S)-J	0.5	0.7		1.2	1.7		2.4		3.4	4.8	5.9
3/4"	Z2075Q(S)-K	0.5	1.0		1.5	2.3		3.3		4.6	6.6	9.8
1"	Z2100Q(S)-K	0.5	0.9		1.5	2.2		3.1		4.3	6	8.2
Runtime (seconds)		30	37	41	43	49	51	55	58	62	68	75

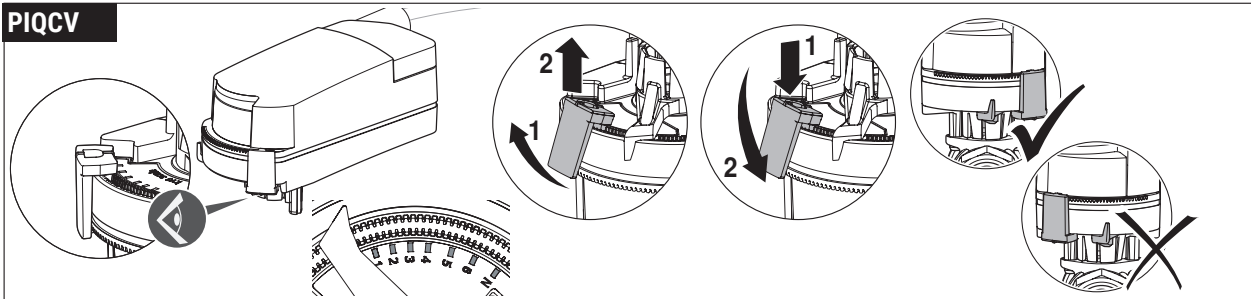

Valve Model	Clip Position for Flow Adjustment (GPM)																			
	1	1+	2-	2	2+	3-	3	3+	4-	4	4+	5-	5	5+	6-	6	6+	N-	N	No Clip
1/2"			0.1					0.2			0.3		0.4		0.5		0.6	0.7	0.8	0.9
Z2050QPT-B																				
Z2050QPT-D	0.2			0.3			0.4	0.5		0.6	0.7	0.8	0.9	1.0	1.2	1.3	1.5	1.6	1.8	2.0
Z2050QPT-F			0.6			0.7	0.8	0.9	1.0	1.3	1.5	1.7	1.9	2.2	2.5	2.8	3.1	3.3	3.6	4.3
Valve Model 3/4"																				
Z2075QPT-G			1.6	1.8	2.1	2.4	2.7	3.0	3.3	3.7	4.0	4.4	4.9	5.3	5.8	6.3	6.7	7.2	7.7	9.0
Runtime	30	33	35	37	39	41	43	45	47	49	51	53	55	58	60	62	64	66	68	75

NPT Installation

ZoneTight valves are provided with ASME NPT female pipe treads for connection to threaded pipe.

Actuator Attachment for QCV/PIQCV

Attach the actuator to the valve body. Align the actuator guide pins to the valve bonnet openings and press down until a click is heard. To remove the actuator, grasp it with your hand and pull it away from the valve body.

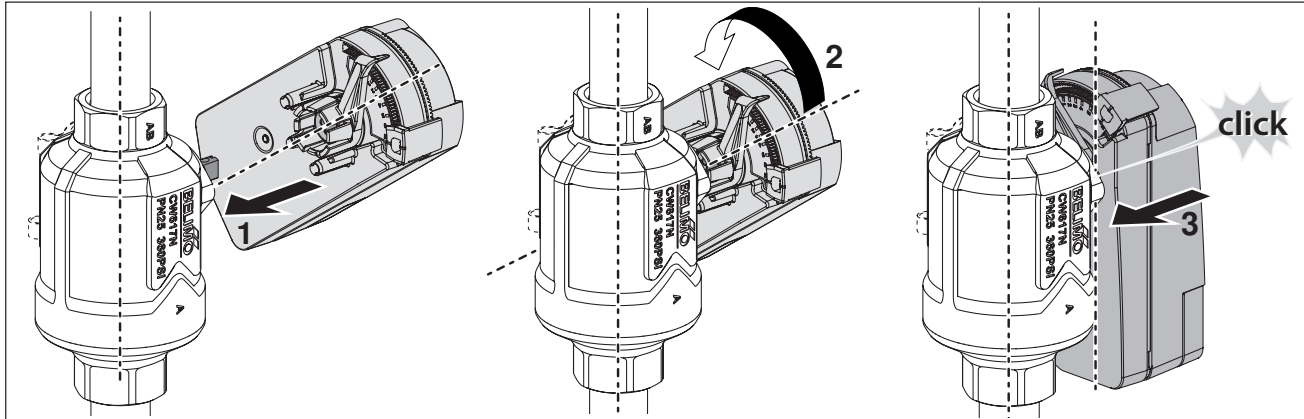

Adaption for Proportional Actuators

For actuators with analog 2-10 VDC signal, after flow capacity adjustment has been field-set by moving the clip to a desired position, execute the adaption routine to scale the signal across the available travel. The actuator will travel first in one direction and stall, then will travel in the opposite direction and stall. Then it will travel to the commanded position of the control signal. When the actuator is powered for the first time the adaption routine will execute automatically. Execute the adaption function any time the clip position is changed. The adaption routine does not change the actuator speed, which is 75 seconds over 90 degree rotation.

For actuators with On/Off or Floating Control input there is no adaption function or button.

Proportional Actuators: CQB24-SR, CQB24-SR-L, CQB24-SR-R, CQKB24-SR, CQKB24-SR-LL, CQKB24-SR-RR, CQKB24-SR-LR, CQKB24-SR-RL

On/Off, Floating Point Actuators: CQB24-3, CQBUP-3

On/Off Actuators: CQKB24, CQKB24-S, CQKBUP

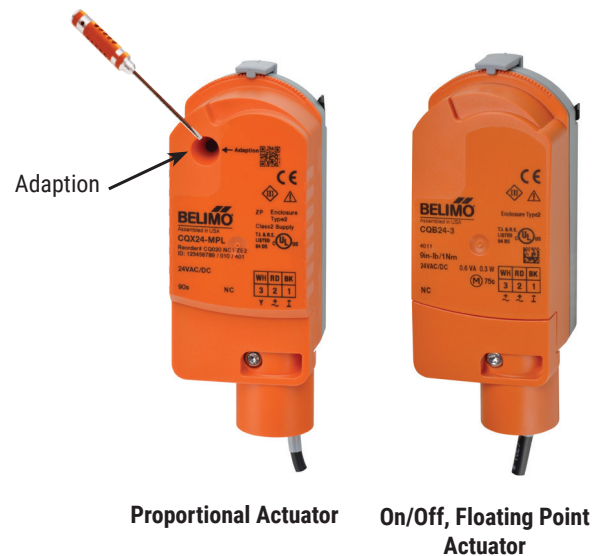

Wiring Diagrams

INSTALLATION NOTES

- (A)** Actuators with appliance cables are numbered.
- 1** Provide overload protection and disconnect as required.
- 2** Actuators may be connected in parallel. Power consumption and input impedance must be observed.
- 3** Actuators may also be powered by 24 VDC.
- 18** Actuators with plenum rated cable do not have numbers on wires; use color codes instead.
- 100** One built-in auxiliary switch (1x SPST), for end position indication, interlock control, fan startup, etc.

APPLICATION NOTES

- Meets cULus requirements without the need of an electrical ground connection

WARNING Live Electrical Components!
 During installation, testing, servicing and troubleshooting of this product, it may be necessary to work with live electrical components. Have a qualified licensed electrician or other individual who has been properly trained in handling live electrical components perform these tasks. Failure to follow all electrical safety precautions when exposed to live electrical components could result in death or serious injury.

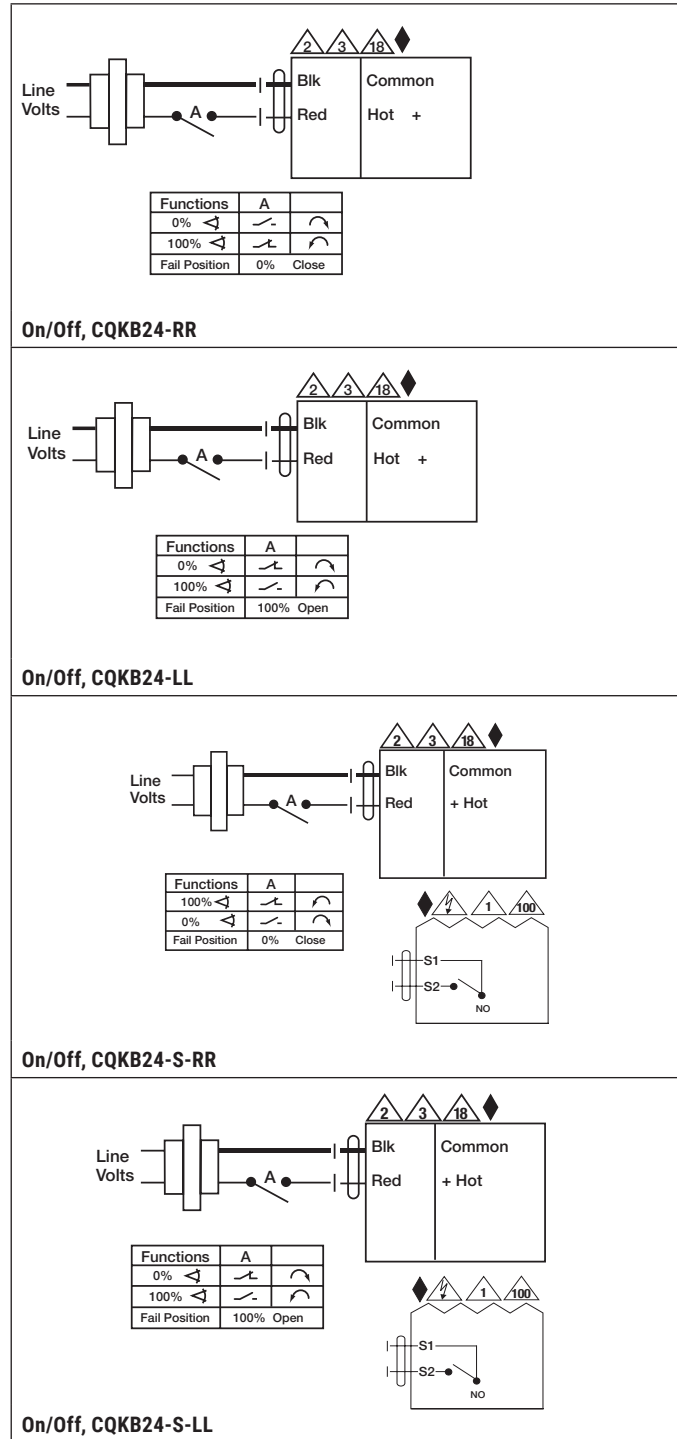
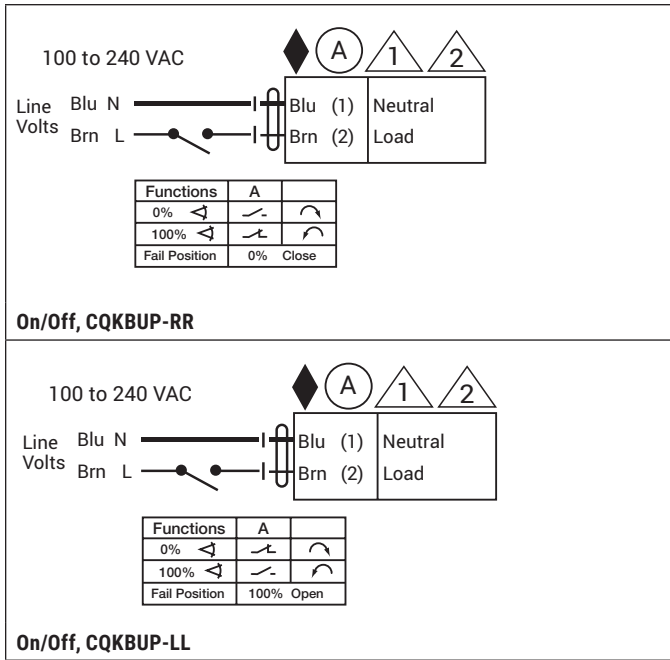

Wiring Diagrams

✂️ INSTALLATION NOTES

- Actuators may be connected in parallel. Power consumption and input impedance must be observed.
- Actuators may also be powered by 24 VDC.
- Only connect common to neg. (-) leg of control circuits.
- A 500 Ω (ZG-R01) converts the 4...20 mA control signal to 2...10 V.
- Actuators with plenum rated cable do not have numbers on wires; use color codes instead.

📄 APPLICATION NOTES

- ◆ Meets cULus requirements without the need of an electrical ground connection

⚠️ WARNING Live Electrical Components!

During installation, testing, servicing and troubleshooting of this product, it may be necessary to work with live electrical components. Have a qualified licensed electrician or other individual who has been properly trained in handling live electrical components perform these tasks. Failure to follow all electrical safety precautions when exposed to live electrical components could result in death or serious injury.

Tech.Doc - 11/24 - Subject to change. © Belimo Aircontrols (USA), Inc.

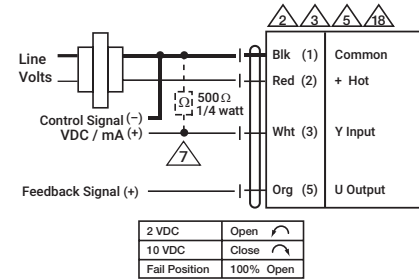

Proportional, CQKB24-SR-LL

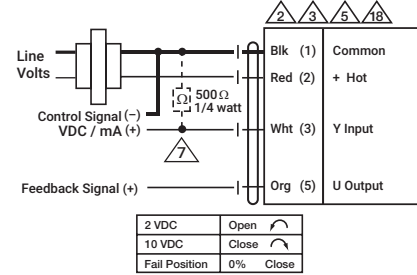

Proportional, CQKB24-SR-LR

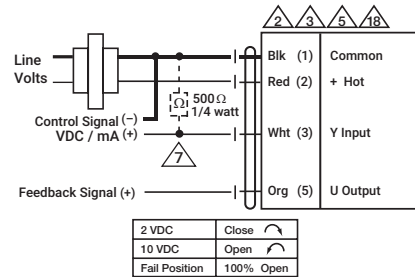

Proportional, CQKB24-SR-RL

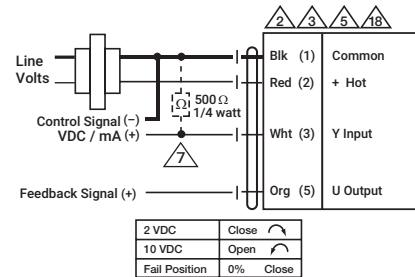

Proportional, CQKB24-SR-RR

Wiring Diagrams

✂️ INSTALLATION NOTES

- ⚠️ 2 Actuators may be connected in parallel. Power consumption and input impedance must be observed.
- ⚠️ 3 Actuators may also be powered by 24 VDC.
- ⚠️ 5 Only connect common to neg. (-) leg of control circuits.
- ⚠️ 7 A 500 Ω (ZG-R01) converts the 4...20 mA control signal to 2...10 V.
- ⚠️ 18 Actuators with plenum rated cable do not have numbers on wires; use color codes instead.

📄 APPLICATION NOTES

- ◆ Meets cULus requirements without the need of an electrical ground connection

⚠️ WARNING Live Electrical Components!
 During installation, testing, servicing and troubleshooting of this product, it may be necessary to work with live electrical components. Have a qualified licensed electrician or other individual who has been properly trained in handling live electrical components perform these tasks. Failure to follow all electrical safety precautions when exposed to live electrical components could result in death or serious injury.

24 VAC Transformer

Functions	A	
100%	↗	↶
0%	↘	↷

On/Off, CQB24-3

Functions	A	B	
0%	↗	↘	↶
100%	↘	↗	↷

Floating Point, CQB24-3

2 VDC	Open	↶
10 VDC	Close	↷

Proportional, CQB24-SR-L

2 VDC	Close	↷
10 VDC	Open	↶

Proportional, CQB24-SR-R

110 to 230 VAC

Functions	A	
100%	↗	↶
0%	↘	↷

On/Off, CQBUP-3

Functions	A	B	
0%	↗	↘	↶
100%	↘	↗	↷

Floating Point, CQBUP-3

PIQCV Flow Verification and Commissioning Overview without Flow Orifice Device

After the actuator travel limit clip has been correctly located to position 1-N (or removed) to match the maximum flow setting of the coil, the following procedures detail the flow verification and commissioning procedures for Pressure Independent Valves Quick Compact Valves (PIQCV). These procedures are not mandatory to ensure proper operation of PIQCV. PIQCVs are very different from pressure dependent control valves (standard control valves). Pressure variations in the system do not affect flow through the PIQCV. Additional flow regulating devices (e.g. circuit setters and automatic flow limiting devices) should not be used in conjunction with PIQCVs. This makes the Testing and Balancing (TAB) or commissioning process much different from standard control valves. PIQCVs offer numerous maximum design flow values in each valve body size. It is important to note that the valve will travel to 90 degrees only when there is no end stop.

External P/T ports allow for independent verification of proper PIQCV operation. Additionally, these ports allow for future comprehensive troubleshooting and diagnosis. For proper and accurate flow verification of the mechanical PIQCV, it is essential that the mechanical contractor install P/T port A.

- P/T port A (P1) are used for measuring pressure differential across the coil (used to measure water ΔP to equate to flow) or to measure water ΔT across the coil.
- P/T port P1 and P3 are used to measure ΔP across the PIQCV assembly. PIQCVs must have 5 – 50 psid (11.5 ft. – 115 ft. H₂O) differential pressure within this range. Do not manually remove the actuator travel limit clip to fully open the valve to check for design flow or pressure. Valve shall be commanded to design flow position via analog or BMS (Building Management System) signal. The required operating differential pressure range is necessary to insure pressure independent operation of the PIQCV

Note: The flow setter (ZCQB-FL) can be used to adjust the flow if the BMS is not available during the commissioning process.

Mechanical PIQCV Pre-Flow Verification Checklist

- Verify that system is purged of air and filled to proper pressure.
- Verify that each PIQCV has the required operating differential pressure range across P/T ports P1 and P3 as shown in fig. A.
- Verify proper pump operation per manufacturer's specifications.
- Verify proper supply water temperature is available and is at design temperature.
- Proper air filter maintenance has been completed.
- Fan belts are in proper working order.
- Heat transfer devices (coils) are clean.
- Strainers are clean.
- All manual shutoff valves are open.
- All bypass valves are closed.
- No automatic or manual balancing valves exist. If they do exist, they must be set fully open and locked to not interfere with the pressure independency function of the PIQCV.

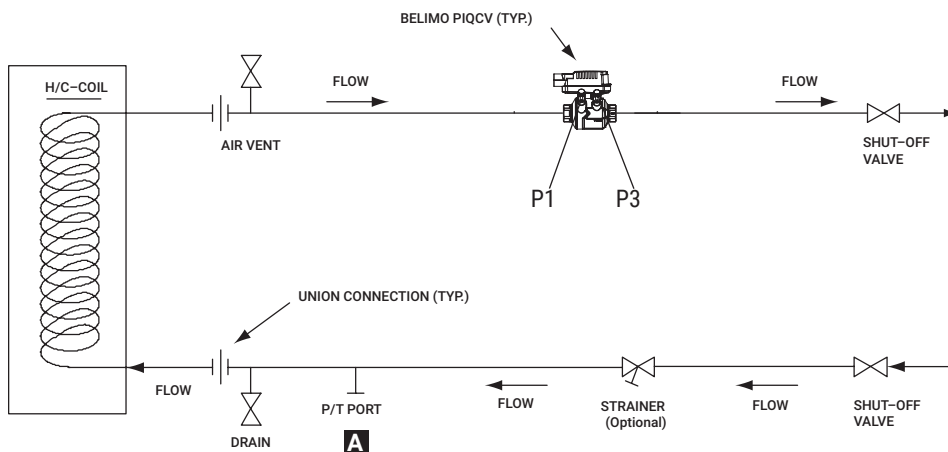

Procedures without Flow Orifice Device

Procedure #1 (System Verification) – Total System Flow Method

Verification for PIQCV Cooling/Heating

1. Verify that the system is in proper working order. Depending on the valves used, check the items listed for PIQCV Pre-Flow Verification Checklists.
2. If diversity factor = 100%, command open all PIQCV's via the BMS system. Systems with less than 100% diversity need to have a number of valves closed to match design diversity.
3. Ensure that pumps are either manually commanded to sufficient speed to provide proper differential pressure across all valves OR if pumps are under DDC pressure control ensure ΔP setpoint is sufficient to provide the above conditions.
- Verify total system flow in main return line is at system design flow rate using one of the following methods: Orifice, Venturi, Electronic flow meter, System-level Flow Device
1. Decrease the pump speed (or decrease ΔP setpoint if under control) until a measureable flow decrease occurs.
2. Increase pump speed (or increase ΔP setpoint if under control) slowly until design flow is reestablished. Make note of the resulting ΔP . This will be the maximum system ΔP operating setpoint.

Note: If total flow does not match design flow then troubleshooting must be done to determine cause. This may involve verifying flows at the terminal level.

Procedure #2 (Terminal Level Verification) – Air Delta T Method

Verification for PIQCV Cooling/Heating

1. Verify that the system is in proper working order. Depending on the valves used, check the items listed for PIQCV Pre-Flow Verification Checklists.
2. Ensure that water is at design temperature.
3. Ensure that terminal airflow is at design airflow rate (cfm).
4. Command open the PIQCV via analog or BMS control signal to maximum design flow position. (Do not manually open the PIQCV beyond the actuator travel limit clip position).
5. Reference approved engineering document containing design air temperature drop/rise for design conditions.
6. Measure coil inlet air temperature and coil discharge air temperature.
7. Difference between coil inlet air reading (EAT) and coil discharge air reading (LAT) should equal to or exceed design air delta T as shown on the contract documents.

Procedure #3 (Terminal Level Verification) – Water Delta Method

Verification for PIQCV Cooling/Heating

1. Verify that the system is in proper working order. Depending on the valves used, check the items listed for PIQCV Pre-Flow Verification Checklists. Ensure that water is at design temperature.
2. Ensure that terminal airflow is at design flow rate (cfm) or water coil airflow is unencumbered.
3. Command open the PIQCV via analog or BMS control signal to maximum design flow position. (Do not manually open the PIQCV beyond the actuator travel limit clip position.)
4. Reference approved engineering document containing design water temperature drop/rise for design conditions.
5. Measure water temperature differential of coil by using P/T ports A and B (or A and P1) as referenced in Fig. A.
6. Measured temperature differential should be equal to designed water temperature differential (EWT, LWT) as shown on the contract documents.

Procedure #4 (Terminal Level Verification) – Coil ΔP (Delta P) Method

Verification for PIQCV Cooling/Heating

1. Verify that the system is in proper working order. Depending on the valves used, check the items listed for PIQCV Pre-Flow Verification Checklists.
2. Command open the PIQCV via analog or BMS control signal to maximum design flow position. (Do not manually open the PIQCV beyond the actuator travel limit clip position.)
3. Ensure ΔP across valve assembly between P/T ports B and C (or P1 and P3) as shown above in Fig. A is within manufacturer's operating parameters.
4. Reference approved engineering document containing design coil water pressure drop (usually expressed in ft. of water) for design flow conditions. This value will be for the heating/cooling coil associated with corresponding PIQCV.
5. Measure coil ΔP by using P/T ports A and B (or A and P1) as referenced in Fig. A.
6. Formula to calculate flow is: $\text{Actual GPM} = \text{Design GPM} \times \sqrt{\frac{\text{Measured Coil } \Delta P}{\text{Design Coil } \Delta P}}$

Note: Measured Coil ΔP and Design Coil ΔP must be expressed in the same engineering units (feet of water, inches of water, psi, etc.).

Flow Verification with Flow Orifice Device

- Belimo flow orifice device has two pressure ports for field ΔP measurement with a manometer gauge.
- Connect manometer high pressure line to flow orifice red PT port; connect low pressure line to green PT port. Follow gauge instructions to verify connections.
- Take ΔP reading in inches of water (w.c.) and transpose to the Flow Orifice line of the Flow Chart. From that point follow the corresponding chart line to the flow scale and determine the actual flow.
- Refer to field-set procedure section on page 14 to adjust flow capacity to meet project requirements.

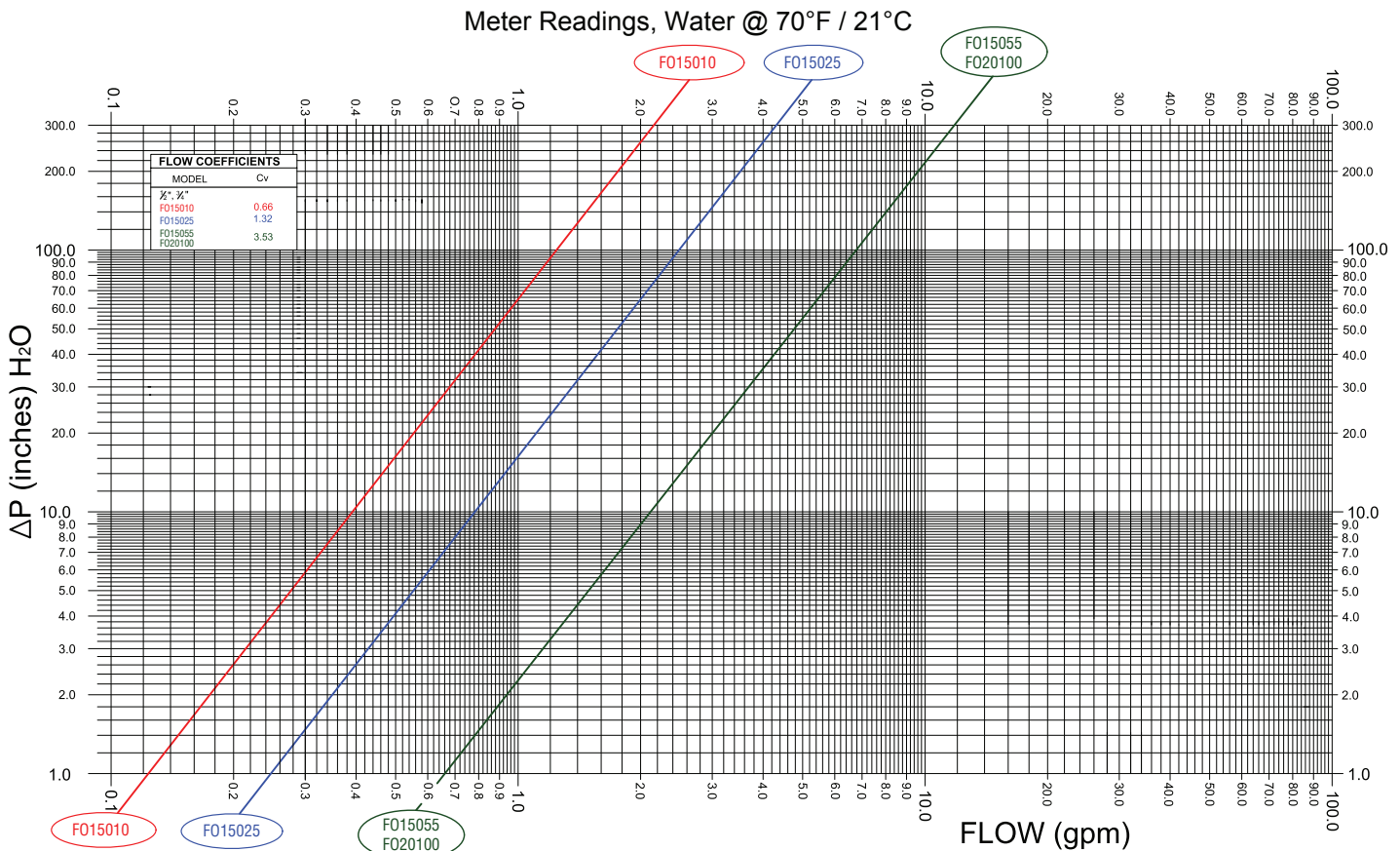

Tech.Doc - 11/24 - Subject to change. © Belimo Aircontrols (USA), Inc.

For Exact GPM or ΔP
 $GPM = \sqrt{\Delta P} \times (Cv / 5.3)$
 $\Delta P = (GPM \times 5.3 / Cv)^2$

Temperature Correction Factor:
 155°F / 68°C = 1.01 x GPM
 205°F / 96°C = 1.02 x GPM

How to Determine Flow:

1. Enter the chart with the ΔP (differential pressure) reading.
2. Go horizontally across to the size of the valve.
3. Go vertically up or down to read the GPM (flow).

Problem	Field Observations	Possible Solution
Actuator will not move.	Actuators wires are connected.	Verify the power supply and control signal are wired and operating correctly. Remove the actuator from the valve body and use the actuator or a slotted screwdriver to move the valve stem to verify free rotation.
Actuator does not modulate with the control signal as expected.	Valve throttles to a different position than expected.	For 3-point floating signals the actuator runtime is relative to the travel set by the clip. The controller runtime parameter may need to be adjusted to match the runtime of the actuator.
Valve is yielding flow but cannot be commanded to the full flow setting	Valve is partially open but will not move to a full open position with a full signal command.	For analog actuators the adaption function may have previously occurred to a lesser angle of rotation than now exists. Press the adaption button and the actuator will re-scale to the full travel set by the clip position.
Full flow is lower than expected.	Clip may be in the wrong position.	The clip may need to be adjusted to a greater angle of rotation to allow more flow, or removed to obtain maximum flow capacity. Refer to the flow commissioning instructions (page 18) for adjustment and verification procedures.
Desired flow cannot be reached.	Valve is wide open.	Increase the pump differential pressure to resolve low flow problems.
Flow measurements are not stable.	Air may be in the system.	Remove air from the system to solve the problem.

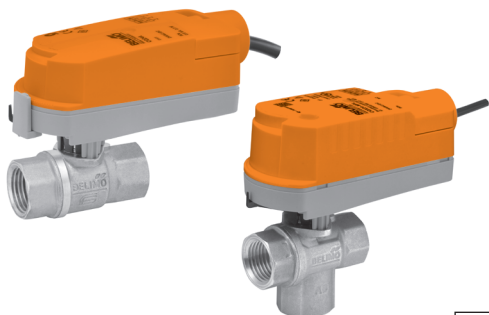

Valve Specifications

Service	chilled or hot water, 60% glycol
Flow characteristic	equal percentage (2-way), linear (3-way)
Controllable flow range	75° (2-way), 90° (3-way)
Size	½", ¾", 1"
Type of end fitting	NPT female ends
Materials	
Body	forged brass
Ball	chrome plated brass
Stem	brass
Seats	Teflon® PTFE
O-rings	EPDM (lubricated)
Media temperature range	21°F to 212°F [-6°C to 100°C]
Media temperature limit*	250°F [120°C]
Max. allowable operating temp.	212°F [100°C]
Body pressure rating	360 psi
Close-off pressure	75 psi
Maximum differential pressure (ΔP)	40 psi
Leakage	0%

*If temperature exceeds 212°F [100°C] operating range due to a boiler control failure the valve will safely contain the hot water but manufacturers product warranty becomes invalid.

Application

The QCV zone valves are suited for large commercial buildings where higher close-off and the ability to change flow is desired. Common applications include unit ventilators, fan coil units, VAV reheat coils, fin tube casing, radiant panels and duct coils. The valve fits in space restricted areas and can be assembled without the use of tools.

Dimensions 2-Way

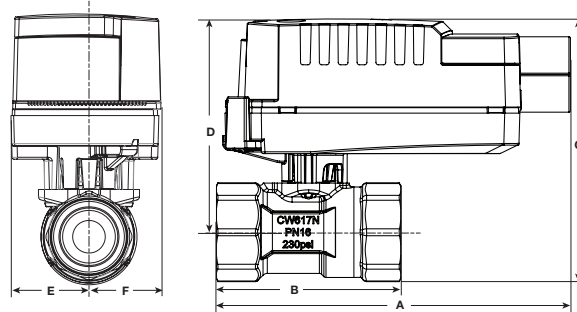

Valve

Nominal Size		Dimensions (Inches [mm])					
In.	DN [mm]	A	B	C	D	E	F
½" Non-Spring Return	15	4.5" [114]	2.05" [52]	3.27" [83]	2.71" [69]	1.88" [48]	1.88" [48]
¾" Non-Spring Return	20	4.5" [114]	2.4" [61]	3.42" [86.9]	2.77" [70]	0.94" [24]	0.94" [24]
1" Non-Spring Return	25	4.7" [120]	2.8" [72]	3.5" [88]	2.8" [70]	0.9" [24]	0.9" [24]
½" Fail-Safe	15	4.5" [114]	2.05" [52]	3.27" [83]	2.71" [69]	0.94" [24]	0.94" [24]
¾" Fail-Safe	20	4.5" [114]	2.4" [61]	3.42" [86.9]	2.77" [70]	1.88" [48]	1.88" [48]
1" Fail-Safe	25	4.7" [120]	2.8" [72]	3.5" [88]	2.8" [70]	0.9" [24]	0.9" [24]

Dimensions 3-Way

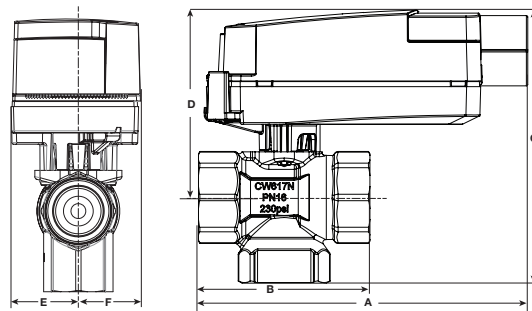

Valve

Nominal Size		Dimensions (Inches [mm])					
In.	DN [mm]	A	B	C	D	E	F
½" Non-Spring Return	15	4.5" [114]	2.05" [52]	3.83" [97]	2.71" [69]	1.02" [26]	1.02" [26]
¾" Non-Spring Return	20	4.5" [114]	2.4" [61]	3.98" [101]	2.77" [70]	1.2" [31]	1.2" [31]
1" Non-Spring Return	25	4.7" [120]	2.8" [72]	5.1" [129]	2.8" [70]	1.2" [30]	1.2" [30]
½" Fail-Safe	15	4.5" [114]	2.05" [52]	3.83" [97]	2.71" [69]	1.02" [26]	1.02" [26]
¾" Fail-Safe	20	4.5" [114]	2.4" [61]	3.98" [101]	2.77" [70]	1.2" [31]	1.2" [31]
1" Fail-Safe	25	4.7" [120]	2.8" [72]	5.1" [129]	2.8" [70]	1.2" [30]	1.2" [30]

Belimo ZoneTight Zone Valves

Chrome Plated Brass Ball, Sweat Connection

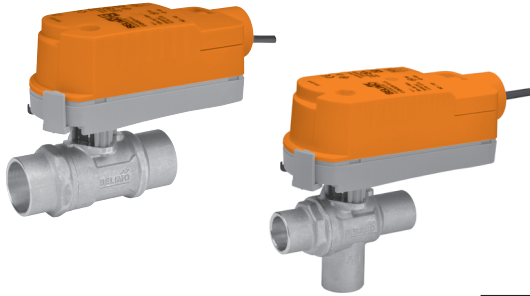

5-year warranty



Valve Specifications

Service	chilled or hot water, 60% glycol
Flow characteristic	equal percentage (2-way), linear (3-way)
Controllable flow range	75° (2-way), 90° (3-way)
Size	½", ¾", 1"
Type of end fitting	sweat
Materials	
Body	forged brass
Ball	chrome plated brass
Stem	brass
Seats	Teflon® PTFE
O-rings	EPDM (lubricated)
Media temperature range	36°F to 212°F [2°C to 100°C]
Media temperature limit*	250°F [120°C]
Max. allowable operating temp.	212°F [100°C]
Body pressure rating	360 psi
Close-off pressure	75 psi
Maximum differential pressure (ΔP)	40 psi
Leakage	0%

*If temperature exceeds 212°F [100°C] operating range due to a boiler control failure the valve will safely contain the hot water but manufacturers product warranty becomes invalid.

Application

The QCV zone valves are suited for large commercial buildings where higher close-off and the ability to change flow is desired. Common applications include unit ventilators, fan coil units, VAV reheat coils, fin tube casing, radiant panels and duct coils. The valve fits in space restricted areas and can be assembled without the use of tools.

Dimensions 2-Way

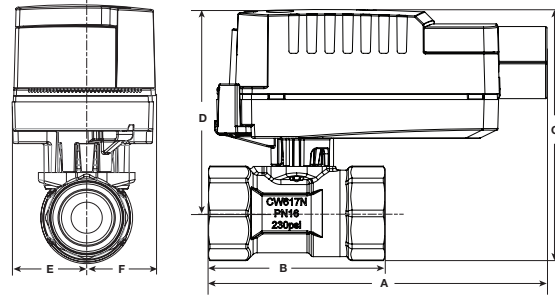

Valve Nominal Size		Dimensions (Inches [mm])					
In.	DN [mm]	A	B	C	D	E	F
½" Non-Spring Return	15	4.78" [122]	2.6" [67]	3.14" [80]	2.56" [66]	1.02" [26]	1.02" [26]
¾" Non-Spring Return	20	4.95" [126]	2.95" [75]	3.28" [84]	2.64" [68]	1.2" [31]	1.2" [31]
1" Non-Spring Return	25	5.1" [129]	3.5" [89]	3.5" [88]	2.8" [70]	0.9" [24]	0.9" [24]
½" Fail-Safe	15	4.95" [126]	2.95" [75]	3.28" [84]	2.64" [68]	1.2" [31]	1.2" [31]
¾" Fail-Safe	20	4.78" [114]	2.6" [67]	3.14" [80]	2.56" [66]	1.02" [26]	1.02" [26]
1" Fail-Safe	25	5.1" [129]	3.5" [89]	3.5" [88]	2.8" [70]	0.9" [24]	0.9" [24]

Dimensions 3-Way

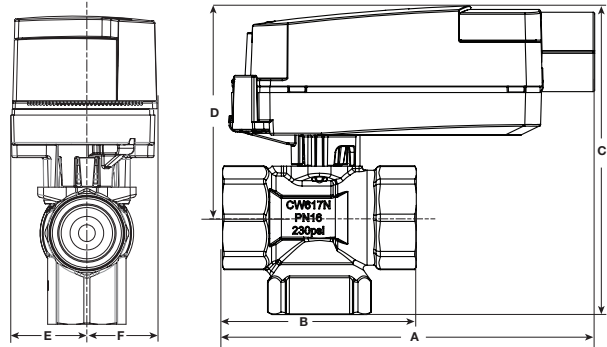

Valve Nominal Size		Dimensions (Inches [mm])					
In.	DN [mm]	A	B	C	D	E	F
½" Non-Spring Return	15	4.78" [122]	2.6" [67]	3.14" [80]	2.56" [65]	1.02" [26]	1.02" [26]
¾" Non-Spring Return	20	4.95" [126]	2.95" [75]	3.28" [84]	2.64" [68]	1.2" [31]	1.2" [31]
1" Non-Spring Return	25	5.3" [134]	3.9" [99]	5.6" [141]	2.8" [70]	1.2" [30]	1.2" [30]
½" Fail-Safe	15	4.78" [122]	2.6" [67]	3.14" [80]	2.56" [65]	1.02" [26]	1.02" [26]
¾" Fail-Safe	20	4.95" [126]	2.95" [75]	3.28" [84]	2.64" [68]	1.2" [31]	1.2" [31]
1" Fail-Safe	25	5.3" [134]	3.9" [99]	5.6" [141]	2.8" [70]	1.2" [30]	1.2" [30]

Tech.Doc - 11/24 - Subject to change. © Belimo Aircontrols (USA), Inc.



5-year warranty



Valve Specifications

Service	chilled or hot water, 60% glycol
Flow characteristic	equal percentage
Controllable flow range	75°
Size	½", ¾"
Type of end fitting	NPT female ends
Materials	
Body	forged brass
Ball	stainless steel
Stem	stainless steel
Stem packing	EPDM (lubricated)
Seats	Teflon® PTFE
O-rings	PTFE
Seat o-rings	EPDM
Spring	stainless steel
Media temperature range	36°F to 212°F [2°C to 100°C]
Media temperature limit*	250°F [120°C]
Max. allowable operating temp.	212°F [100°C]
PT ports	included
Body pressure rating	360 psi
Close-off pressure	200 psi
Differential pressure (ΔP) range	5 to 50 psi
Leakage	0%

*If temperature exceeds 212°F [100°C] operating range due to a boiler control failure the valve will safely contain the hot water but manufacturers product warranty becomes invalid.

Application

The PIQCV zone valves with its pressure independent technology are suited for large commercial buildings where higher close-off and dynamic balancing is required. Common applications include unit ventilators, fan coil units, VAV reheat coils, fin tube casing, radiant panels and duct coils. The valve fits in space restricted areas and can be assembled without the use of tools.

Dimensions

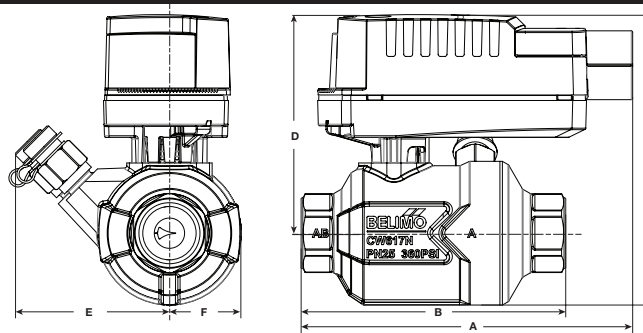

Valve Nominal Size		Dimensions (Inches [mm])					
In.	DN [mm]	A	B	C	D	E	F
½"	15	4.90" [124.5]	4.17" [106]	4.50" [114.3]	3.43" [87]	2.44" [62]	1.30" [31.5]
Non-Spring Return							
¾"	20	5.00" [127]	4.65" [118]	5.00" [127]	3.43" [87]	2.60" [66]	1.52" [38.5]
Non-Spring Return							
½"	15	4.90" [124.5]	4.17" [106]	4.79" [122]	3.50" [89]	2.44" [62]	1.30" [31.5]
Fail-Safe							
¾"	20	5.00" [127]	4.65" [118]	5.16" [131]	3.58" [91]	2.60" [66]	1.52" [38.5]
Fail-Safe							

Belimo ZoneTight Zone Valves

Non-Spring Return and Fail-Safe Actuator Series



Operation

The ZoneTight Zone Valves (QCV, PIQCV) are operated by rotary actuators. The actuators are controlled by a standard voltage for on/off control, proportional signal, or 3-point control system which move the ball of the valve to the position dictated by the control system.

Non-Spring Return CQ.., CQ..UP Fail-Safe Actuators CQK.., CQK..UP

Actuator Specifications	
Power supply	24V (110-230 VAC, UP series)
Manual override	use actuator or slotted screwdriver to turn valve stem
Power consumption	
CQ...	0.3 W running, 0.2 W holding
CQK...	2.5 W running, 0.5 W holding
CQ..UP	1.0 W running, 0.7 W holding
CQK..UP	3.0 W running, 0.5 W holding
Transformer sizing	
CQ...	0.6 VA
CQK..	5 VA
CQ..UP	2 VA
CQK..UP	7 VA
Electrical connection	3 ft., 18 GA, plenum rated cable ½" conduit connector
Overload protection	
Non-Spring Return	electronic throughout 0° to 90° rotation
Fail-Safe	electronic throughout full stroke
Operation range Y	on/off
Angle of Rotation	90°, adjustable with mechanical stop
Position Indication	pointer
Running Time (Motor)	75 seconds
Running Time (Fail-Safe)	60 seconds
Humidity	5 to 95% RH non-condensing
Ambient Temperature Range	+35°F to +104°F [+1.7°C to +40°C]
Storage Temperature Range	-40°F to +176°F [-40°C TO +80°C]
Housing	NEMA 2, IP40, UL enclosure type 2
Housing Material	UL94-5VA
Agency Listings†	cULus acc. to UL60730-1A/-2-14, CAN/CSA E60730-1:02, CE acc. to 2004/108/EC and 2006/95/EC
Noise Level (Motor)	<35 dB (A)
Servicing	maintenance free
Quality Standard	ISO 9001
Weight	
Non-Spring Return	0.44 lb [0.2 kg]
Fail-Safe	3.6 lbs [1.6 kg]
Quality standard	ISO 9001
Agency listings	UL 60730-1/2-14, 2-18, CE according to 2004/108/EC and 2006/95/EC

Tech.Doc - 11/24 - Subject to change. © Belimo Aircontrols (USA), Inc.

Valve Flow Charts

Two notch positions exist between numbered notches for field-set clip positioning to obtain maximum flow capacity. Refer to charts and set the clip as needed.

QCV Flow Curves

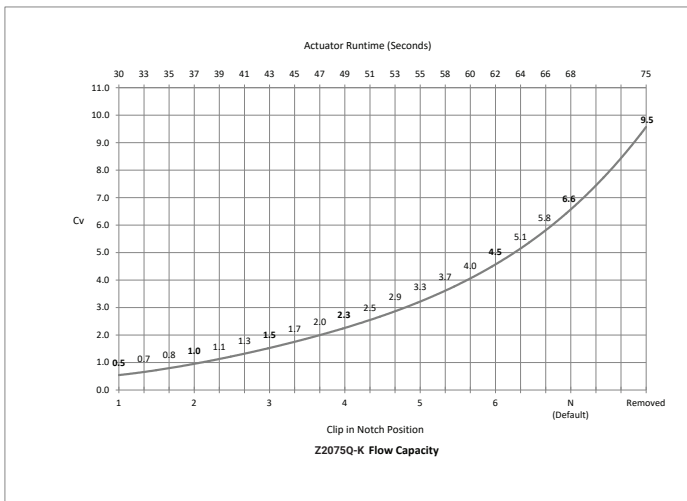
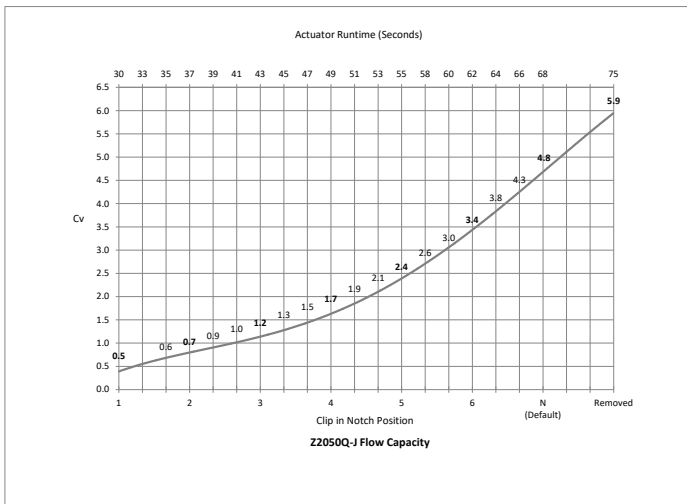
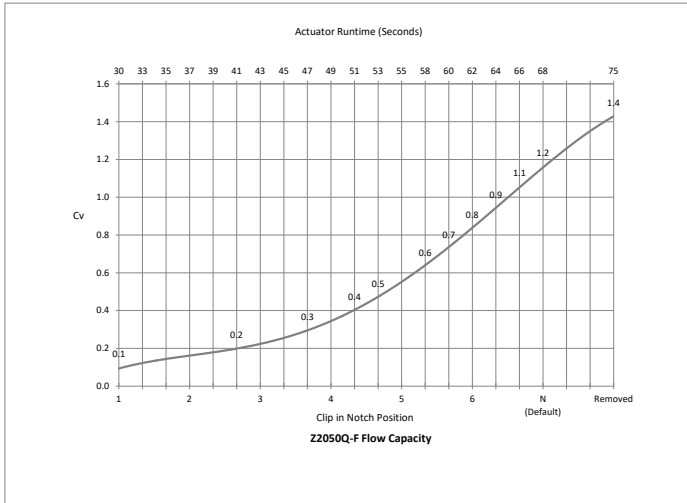

Tech.Doc - 11/24 - Subject to change. © Belimo Aircontrols (USA), Inc.

PIQCV Flow Curves

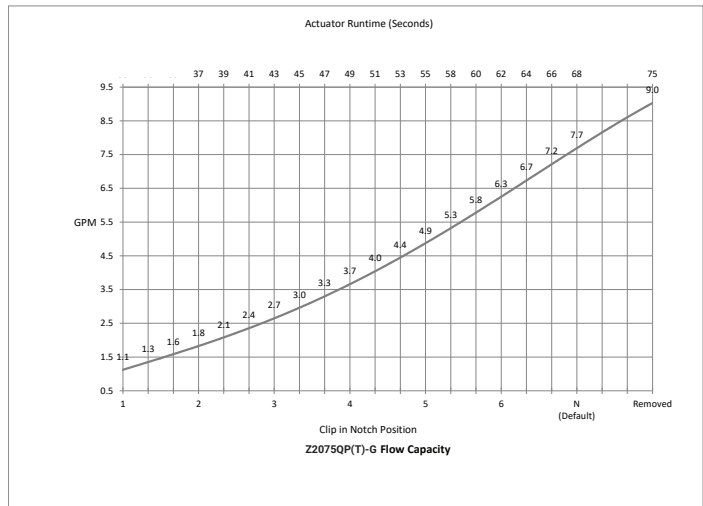
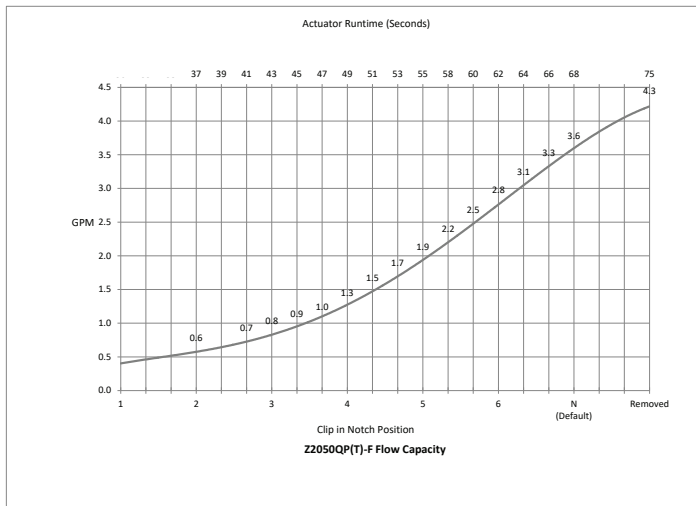
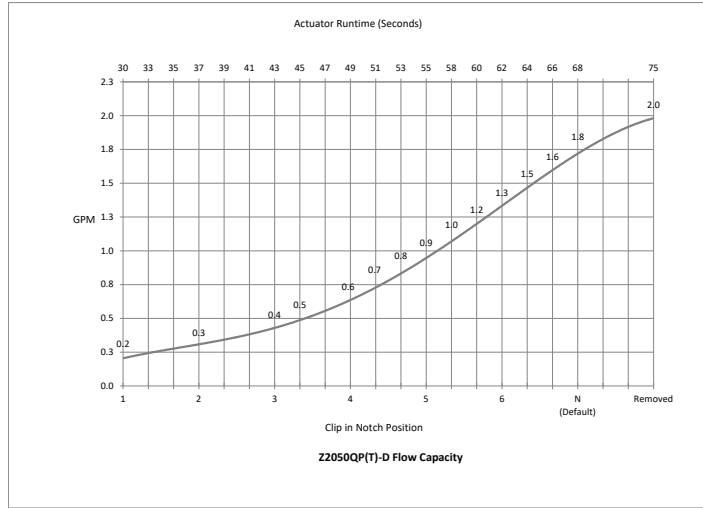
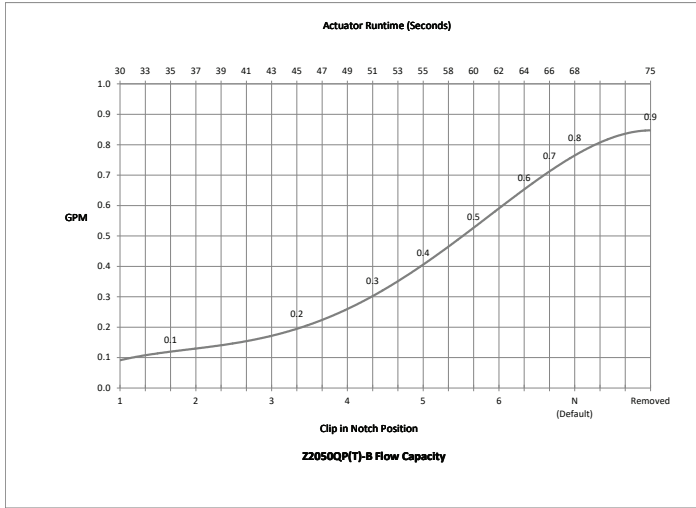

- I. General
- 1.1. The following Terms and Conditions of Sale and Warranty ("Terms") apply to the sale of products described in this Product Guide and products sold by Seller as an original equipment manufacturer ("OEM") which may not be included in this Product Guide ("Product" or "Products"). As used herein, "Seller" or "Belimo" refers to Belimo Aircontrols (USA), Inc., or Belimo Aircontrols (CAN), Inc., or Belimo Automation AG, or Belimo Brasil – Comércio de Automação Ltda. as applicable, and "Client" refers to the individual or business entity that purchases the Products directly from Seller. These Terms shall apply unless the Seller and Client mutually agree to different terms and memorialize such agreement in writing signed by both Client and Seller or (ii) unless Seller changes these Terms and publishes the Terms on its Website to be found at: www.belimo.us, in which case the most recent Terms published on the Website will prevail. In case Seller's delivery includes software and/or application software and accompanying documentation, the terms of the license agreement for such software and/or application software are applicable in addition to these Terms. However, in case of conflicts between the terms and conditions of the license agreement and the Terms, the terms and conditions of the license agreement shall prevail.
- II. Price
- 2.1. The Seller's price for Products (the "Price") is net, F.O.B. Point of Origin, and is calculated in US currency for sales made by Belimo Aircontrols (USA), Inc., and calculated in Canadian currency for sales made by Belimo Aircontrols (CAN) Inc., and Brazilian currency for sales made by Belimo Automation AG or Belimo Brasil – Comércio de Automação Ltda. to Clients in Brazil.
- 2.2. The Price, unless otherwise agreed upon, does not include freight and packaging (wooden crates, pallets, etc.), the costs of which will be charged to Client at cost for each shipment and shall be payable with payment of the Price.
- 2.3. Orders for Products where the total order has a net value of less than US \$300 (CAN \$300) will be subject to a US \$20 (CAN \$20) handling fee (the "Handling Fee"). The Handling Fee will not be charged for orders of Products with a net value equal to or greater than US \$300 (CAN \$300) or for Products ordered through Seller's e-commerce ordering system at: www.belimo.us.
- 2.4. Seller reserves the right to make partial deliveries of orders of Products, each of which deliveries may be invoiced separately by Seller.
- 2.5. The Price does not include charges for wiring diagrams, installation, and commissioning, which will be charged to Client separately and will be payable on demand.
- III. Payment
- 3.1. Invoices are payable in US currency for sales made by Belimo Aircontrols (USA), Inc., and in Canadian currency for sales made by Belimo Aircontrols (CAN); Inc., and in Brazilian currency for sales made by Belimo Automation AG on behalf of Brazil or Belimo Brasil – Comércio de Automação Ltda. Payments on invoices are due no later than 30 days from the date of invoice, without any deductions.
- 3.2. If Client maintains an outstanding balance for 45 days or more after the date of invoice, Client may be subject to restricted shipments of Products. A Client may also be required to pay for all future deliveries of Products on a cash-on-delivery only basis.
- IV. Title and Risk
- 4.1. Title to Products will pass to Client from the Seller based upon the agreed Incoterms as stated on the Order Confirmation. The Seller retains the right to a return of the Product when payment is not received.
- V. Damage or Loss in Transit
- 5.1. Seller assumes no liability for damage or loss of shipment of Products, which risk shall at all times remain with the carrier. All shipments must be unpacked and examined by Client immediately upon receipt. Any external evidence of loss or damage must be noted on the freight bill accompanying the shipment of Products or carrier's receipt and signed by the carrier's agent at the time of delivery. Failure to do so will result in the carrier's refusal to honor any claim relating to damage of Products. Client must also notify Seller within 5 days of such damage by providing Seller with a copy of the freight bill or damage report so that Seller can file a claim for loss or damage in transit with the carrier. If the damage does not become apparent until the shipment is unpacked, Client must make a request for inspection

- by the carrier's agent and file with the carrier within 15 days after receipt of product and notify Seller of the same.
- VI. Delivery
- 6.1. Seller undertakes to make every attempt to adhere to its stated delivery parameters and to make a timely delivery of the Products but does not guarantee any delivery specifications. Each contract entered into for the purchase of Products is not cancelable nor is Seller liable for any direct or indirect losses that may arise, for any reason whatsoever, due to Seller's failure to meet any stated or assumed delivery schedules.
- VII. Inventory Overstock
- 7.1. If Client has an overstock of Product inventory, such Products received by Client cannot be returned unless and until: (i) Client alerts Seller that it intends to return some overstock of Products, (ii) Seller agrees to accept such return, (iii) Client obtains a Return Material Authorization ("RMA") number from Seller for such return of such Products, and (iv) Client follows all return instructions provided by the Seller. The RMA number must be clearly written on the outside of all packaging for any returned overstock of Products.
- 7.2. Only such Products returned in original packaging and shipped to Seller at Client's cost may be accepted for return under this Section. Client is also responsible for payment of a restocking charge for all returned overstocked Products in an amount no less than 20% of the invoice value of the Products ("Restocking Charges"). Any piping package or custom order returns carry a minimum restocking charge of 75% of the invoice value. Returns that result from Seller errors and not overstocking will be credited in full and will not be subject to Restocking Charges.
- 7.3. Any Product received damaged or showing evidence of having been installed will be refused or assessed a higher restocking charge.
- 7.4. If Client requests product to be returned to Client, the Client will be responsible for return shipping charges. See specific product literature for exclusions or exceptions.
- 7.5. Any products that are designed to a Client's unique specifications (e.g. retrofit) are not returnable.
- VIII. Handling, Installation and Use of Products
- 8.1. Products are only intended for installation and commissioning by trained technicians.
- 8.2. The installation and exchange of Products may only be carried out by trained technicians. Products may only be handled by trained technicians and only in accordance with the most current valid data and installation sheets.
- IX. Limited Warranty
- A. 5-year Limited Warranty
- 9.1. Products that are designated by Seller as carrying a 5-year warranty to a location in the United States, Canada, or Latin America shall carry a 5-year warranty. The 5-year warranty is unconditional for the first two years from the date of sale of the Products to Client, subject to the Limitation On Warranty in Section 9C. After the first two years from the date of sale, the warranty coverage shall not apply to damage to Products not resulting from normal wear and tear (e.g. negligence, misuse, or failure to maintain). Product specific terms of warranty with regard to warranty period or conditions of warranty may apply to certain specified Products as stated in the documentation for those Products.
- B. 2-year Conditional Warranty
- 9.2. Products that are designated by Seller as carrying a 2-year warranty to a location in the United States, Canada, or Latin America shall carry a 2-year warranty. The 2-year warranty is conditional from the date of sale of the Products to Client, and the warranty coverage shall not apply to damage to Products not resulting from normal wear and tear (e.g. negligence, misuse, or failure to maintain). Product specific terms of warranty with regard to warranty period or conditions of warranty may apply to certain specified Products as stated in the documentation for those Products.
- C. Limitation On Warranty; Warranty Disclaimer
- 9.3. Seller's warranties hereunder shall be null and void in the event of any: (a) modification or unauthorized repairs of Products by Client; (b) unauthorized incorporation or integration of Products into or with Client's equipment; (c) use of Products in an unauthorized manner; or (d) damage to Products not caused by Seller.

Belimo ZoneTight Zone Valves

Terms and Conditions of Sale and Warranty



9.4. These Terms constitute the entire understanding and agreement between Seller and Client regarding the warranties that cover Products and supersedes all previous understandings, agreements, communications and representations. All Seller warranties are extended only to Client and are non-transferrable. All Seller warranties shall extend only to HVAC use of the Products. If Products are used in non-HVAC applications (e.g., aircraft, industrial processes, etc.), Seller's warranties will not cover such Products. Client will be solely responsible for any damage to or malfunction of Products or for any damage resulting from such use of Products.

9.5. Both the conditional and unconditional warranties hereunder cover the Products only, and do NOT cover labor associated with the troubleshooting, removal or replacement of such Products.

9.6. EXCEPT FOR THE EXPRESS WARRANTIES SPECIFIED IN SECTION IX, SELLER MAKES NO OTHER WARRANTIES, EITHER EXPRESS OR IMPLIED, AND DISCLAIMS ALL OTHER WARRANTIES, INCLUDING BUT NOT LIMITED TO THE IMPLIED WARRANTY OF FITNESS FOR A PARTICULAR PURPOSE AND IMPLIED WARRANTY OF MERCHANTABILITY.

D. Remedies

9.7. If a defect arises in the Product and an RMA is issued as provided in Section 9.8, Seller will, at its option and to the extent permitted by law, either (1) repair the Product at no charge, using new or refurbished replacement parts or (2) replace the Product with a new Product. In the event of such a defect, to the extent permitted by law, these are Client's sole and exclusive remedies.

9.8. Client cannot return Products to Seller unless: (i) Client notifies Seller that it intends to return such Products, (ii) Seller agrees to accept the return of such Products, (iii) Client obtains a RMA number from Seller for the return of such Products, and (iv) Client follows all return instructions provided by the Seller. Client shall promptly notify Seller of Products' alleged defect and provide Seller with other evidence and documentation reasonably requested by Seller. The RMA number must be clearly written on the outside of all packaging for any returned Products. Only Products returned to the proper location as instructed by Seller and identified with an RMA number will be considered for credit.

9.9. Returns that result from Seller's breach of these Terms will be credited in full and will not be subject to Restocking Charges.

9.10. Seller-authorized support technicians are available for troubleshooting before any shipments to Seller. The contact information for Belimo customer service is listed on the back page of Belimo's Product Guide and Price List ("PGPL") or may be found at www.belimo.us.

9.11. If Seller determines that a problem cannot be resolved without Product replacement, an RMA number will be issued by Seller for return of the Products. Prior to returning any Products under a warranty, Client must obtain an RMA number from Seller, along with shipping instructions for the return. The RMA number must be clearly written on the outside of the box containing the returned Products. Only Products returned to the proper location and identified with an RMA number will be accepted by the Seller.

9.12. All returned Products should be packaged appropriately to prevent further damage. Seller reserves the right to refuse any returned Product if improperly packaged or labeled (e.g. without an RMA number on the outside of packaging). Products returned without proper RMA documentation will void Seller's warranty. Seller is not responsible for charges that Client may incur as a result of the removal or replacement of Products.

9.13. Repaired or replacement Products are shipped from Seller via ground shipment. Other shipping methods are available at the sole expense of the Client.

9.14. Repaired, replaced or exchanged Products will carry a warranty for a period of time equal to the greater of: (i) the remainder of the original 5-year warranty or 2-year warranty that was applicable to the repaired, replaced or exchanged Products, or (ii) six months, effective from the date the repaired, exchanged or replaced Products are shipped by Seller (the "Replacement Warranty Period").

9.15. If Seller determines that Product under warranty is to be replaced, Seller may elect to send a replacement in advance of receiving the returned item. For valve products 2½" in diameter or greater, a purchase order is required. An invoice will be issued and shall be due and payable if the returned Products are not received by Seller within 60 days from the date that the replacement Products are shipped. Additional charges may apply if the nature of the problem has been misrepresented by Client.

9.16. New Products ordered in an attempt to circumvent the warranty process may NOT be reimbursed if, upon receipt of returned Products, it is determined that the defect in the returned Products is actually field related, or the Products have been returned for cosmetic reasons only.

X. Liability Disclaimer

10.1. IN NO EVENT SHALL SELLER HAVE ANY LIABILITY TO CLIENT OR ANY THIRD PARTY FOR ANY (a) LOST PROFITS OR COSTS OF PROCUREMENT OF SUBSTITUTE GOODS OR SERVICES, OR FOR ANY INDIRECT, INCIDENTAL, SPECIAL OR CONSEQUENTIAL DAMAGES, OR (b) ANY DAMAGES WHATSOEVER RESULTING FROM THE PERFORMANCE OR A TEMPORARY OR PERMANENT LOSS OF USE OF PRODUCTS, HOWEVER CAUSED UNDER ANY THEORY OF LIABILITY AND WHETHER BASED IN CONTRACT, TORT (INCLUDING NEGLIGENCE), STATUTE OR OTHERWISE. THE FOREGOING LIMITATIONS SHALL APPLY EVEN IF SELLER HAS BEEN ADVISED OF THE POSSIBILITY OF SUCH DAMAGES AND NOTWITHSTANDING THE FAILURE OF ESSENTIAL PURPOSE OF ANY LIMITED REMEDY STATED HEREIN. SELLERS MAXIMUM AGGREGATE LIABILITY UNDER, ARISING FROM OR IN CONNECTION WITH THE SALE OF ITS PRODUCTS TO CLIENT, SHALL BE LIMITED TO THE AMOUNT PAID BY CLIENT FOR THE PRODUCT DEEMED RESPONSIBLE FOR THE LOSS OR DAMAGE.

10.2. Client releases Seller in full from any possible third party claims resulting in connection with the circumstances listed above. This also applies to claims in connection with products liability.

10.3. If Client becomes aware that any third party has made or appears likely to make any claim regarding Products (including, without limitation, regarding Product defects or rights infringed by Products), then Client shall immediately inform Seller and afford to Seller all assistance that Seller may require to enforce its rights and defend such claim.

XI. Proper Law and Jurisdiction

11.1. All sales of Products under these Terms described herein shall be governed by the laws of the State of Connecticut, without regard to its conflicts of law principles, and Seller and Client agree to submit to the exclusive jurisdiction of the federal and state courts located in the State of Connecticut with respect to any dispute arising from the subject matter hereof. The Seller and Client hereby waive all rights to a jury trial in connection with any claims relating to the subject matter hereof. All causes of action arising out of or connected to the sales of Products under these Terms shall be resolved individually, with no right by Seller or Client to participate in a representative capacity, or as a member of any class action.

XII. Privacy and Data

12.1 Seller places great value on the implementation of lawful data processing to protect Client's personal data. Seller is obliged to process Client's personal data in accordance with applicable law. Seller is dependent on the services of a third party for the provision of its services. Seller has obligated the third party to process Client's data only in connection with the services agreed with Seller, to ensure the same level of data protection as Seller, and to not pass on Client's data to other third parties without Client's consent. When processing Client's data and transferring Client's data to third parties, Seller will use reasonable commercial efforts to provide an appropriate level of data protection and that appropriate organizational and technical measures are implemented to protect Client's personal data. More detailed information on Seller's data protection guidelines is available from the following Internet address: www.belimo.com/privacy.

XIII. California Proposition 65

 13.1 WARNING: Some Belimo Products can expose you to chemicals which are known to the State of California to cause cancer, birth defects, or other reproductive harm. Please refer to the Product specific Technical Data sheet at www.belimo.us for details.

For more information see www.p65warnings.ca.gov